

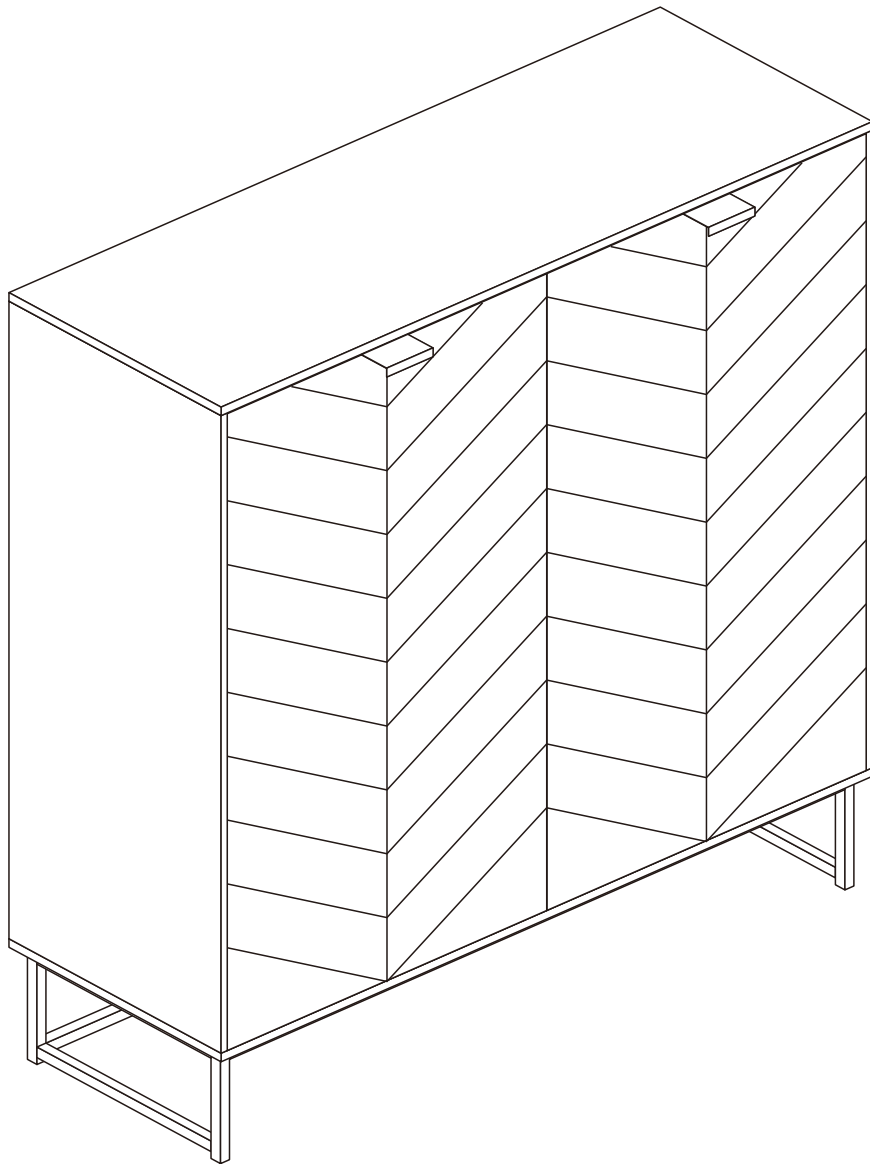













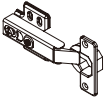

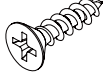
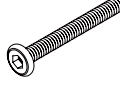
Cabinet

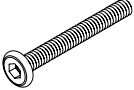

ASSEMBLY INSTRUCTION

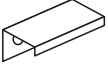
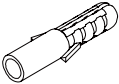
HARDWARE LIST

A 10 PCS		B 10 PCS		C 8 PCS		D 8 PCS		E 2 PCS	
F 4 PCS		G 4 PCS		H 24 PCS		I 6 PCS		J 8 PCS	
K 8 PCS		L 1 PC		M 2 PCS		N 2 PCS		O 2 PCS	
P 2 PCS		Q 4 PCS		R 4 PCS					

PARTS LIST

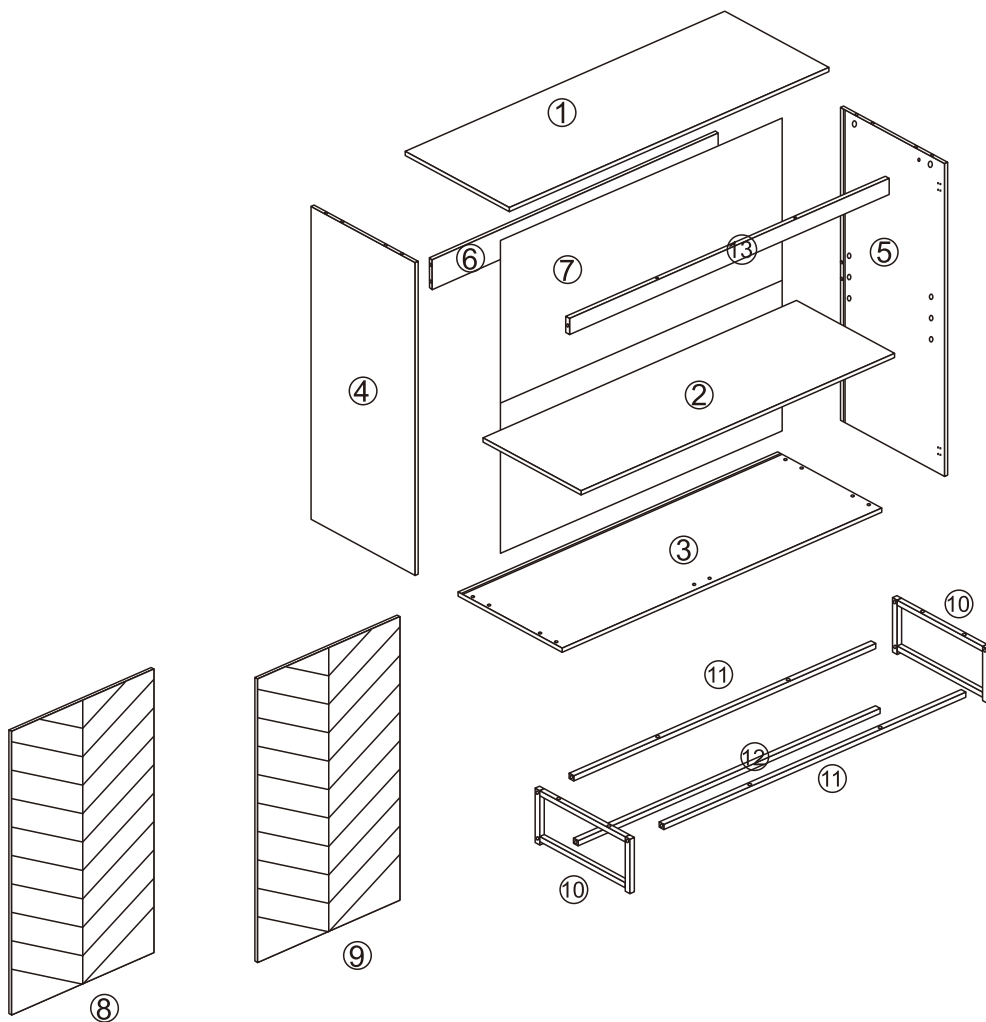

ASSEMBLY STEPS

STEP 1.

Fix parts 11 and 12 to parts 10 using screws (I) and allen key (L), as shown

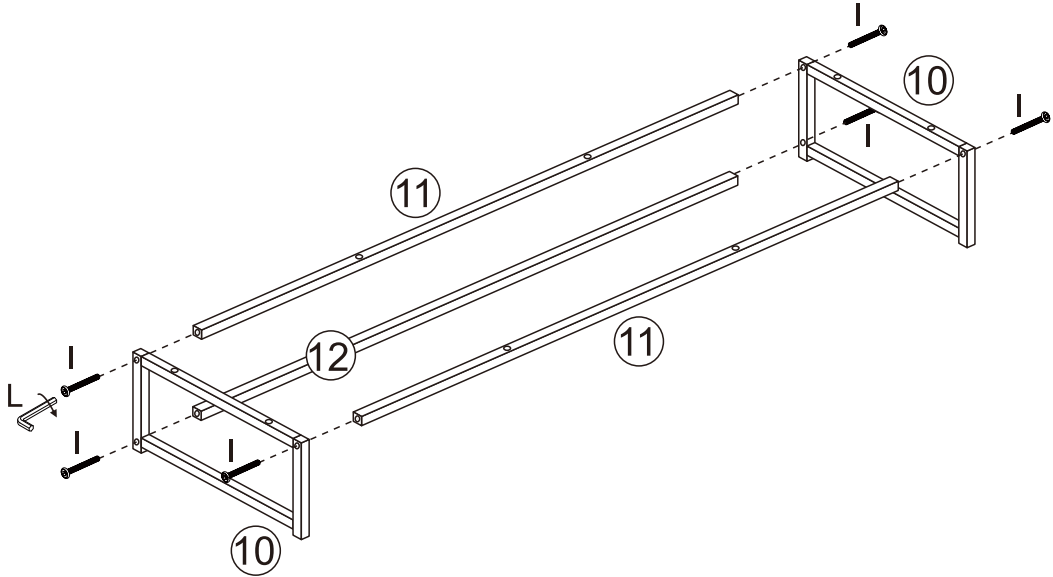

STEP 2.

Fix magnetic door catches (E) to parts 1 and 3 using screws (R), as shown.
Fix wall straps (N) to part 1 and 3 using washers (M) and screws (M), as shown.

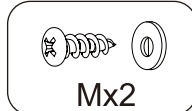
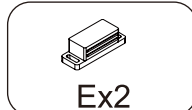
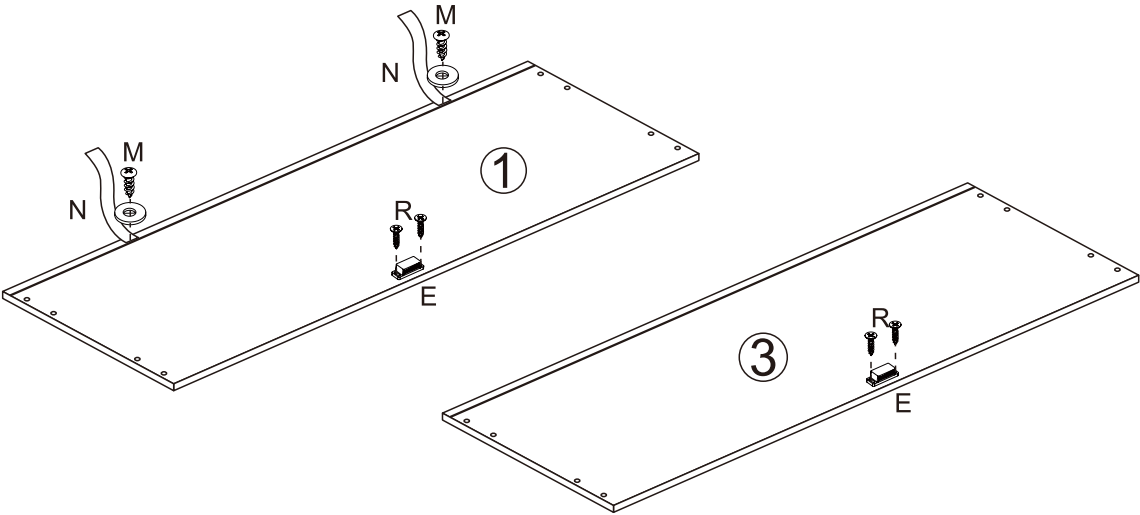

ASSEMBLY STEPS

STEP 3.

Fix hinges (F) to doors 8 and 9 using screws (H), as shown.
 Fix handles (O) and door catch plates (Q) to doors 8 and 9 using screws (J), as shown.

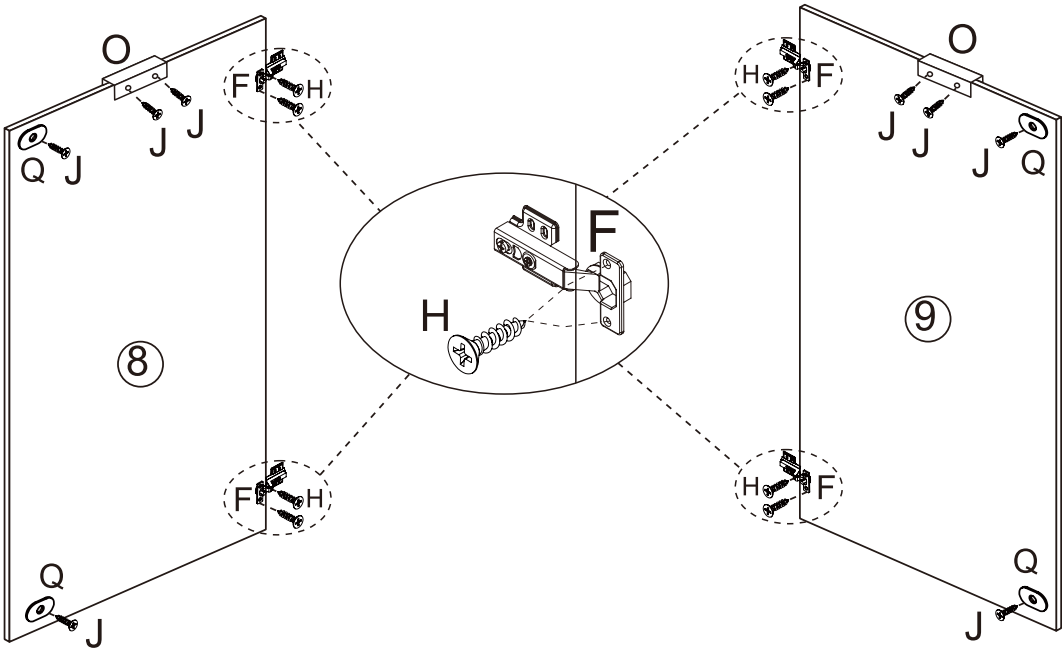

- Fx4
- Jx8
- Hx8
- Ox2
- Qx4

STEP 4.

Insert quickfit screws (A) into parts 4 and 5, as shown.
 Insert cam locks (B) into parts 6 and 13, as shown.
 Fit parts 6 and 13 to parts 4 and 5.
 Turn cam locks clockwise to tighten.

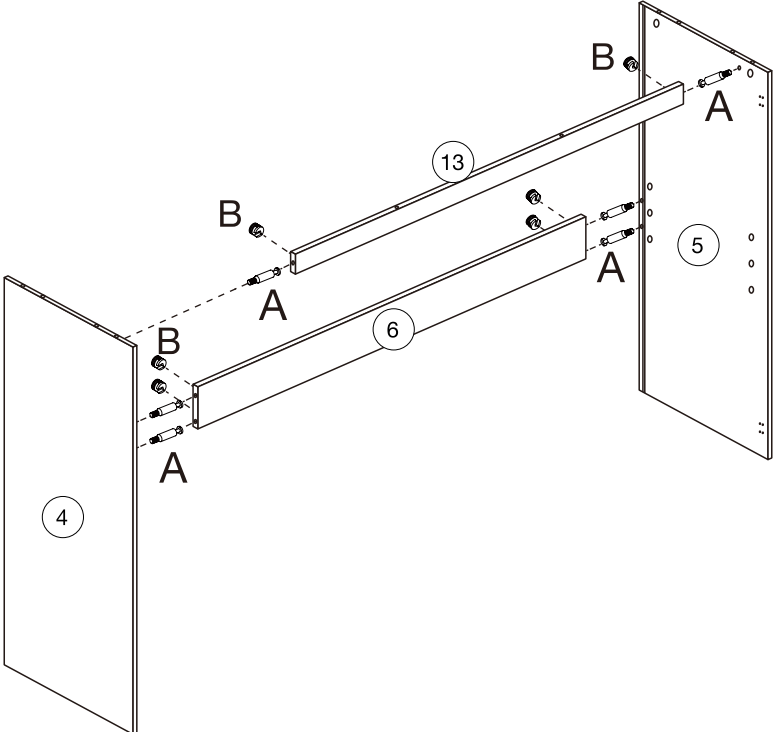

- Ax6
- Bx6

ASSEMBLY STEPS

STEP 5.

Attach part 3 to parts 4 and 5 with wooden dowels (C) and screws (D), as shown.

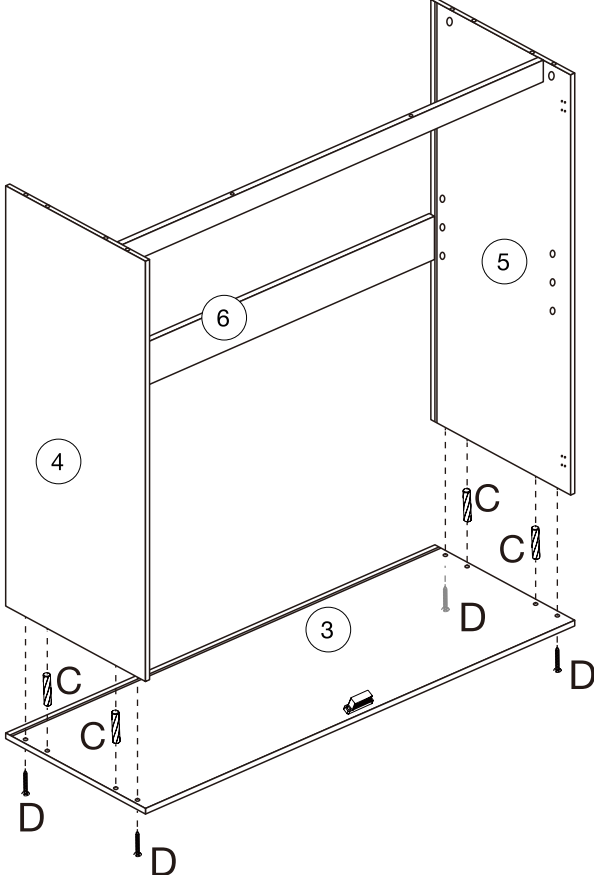

STEP 6.

Slide part 7 into grooves between parts 4, 3 and 5, as shown.

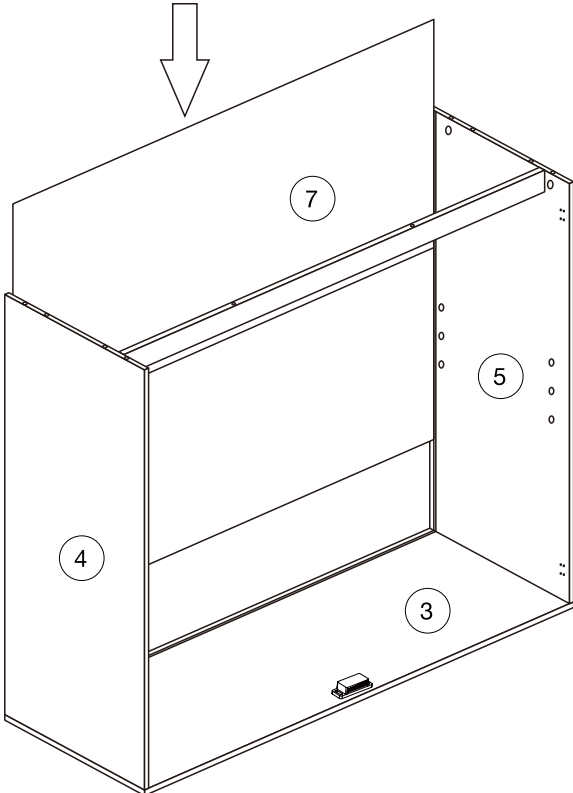

ASSEMBLY STEPS

STEP 7.

Insert quickfit screws (A) and wooden dowels (C) into part 1, as shown.
Insert cam locks (B) into parts 4 and 5, as shown.
Fit part 1 to assembled unit. Turn cam locks clockwise to tighten.

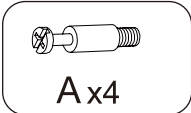
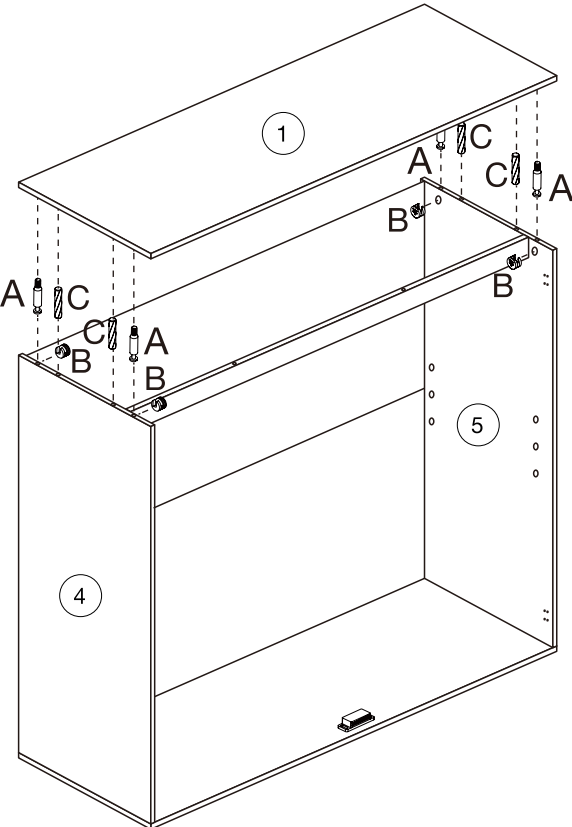

STEP 8.

Fix metal legs (10) to part 3 using screws (K), as shown.
Secure part 13 to part 1 using screws (D), as shown.

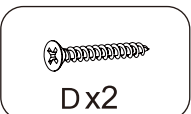
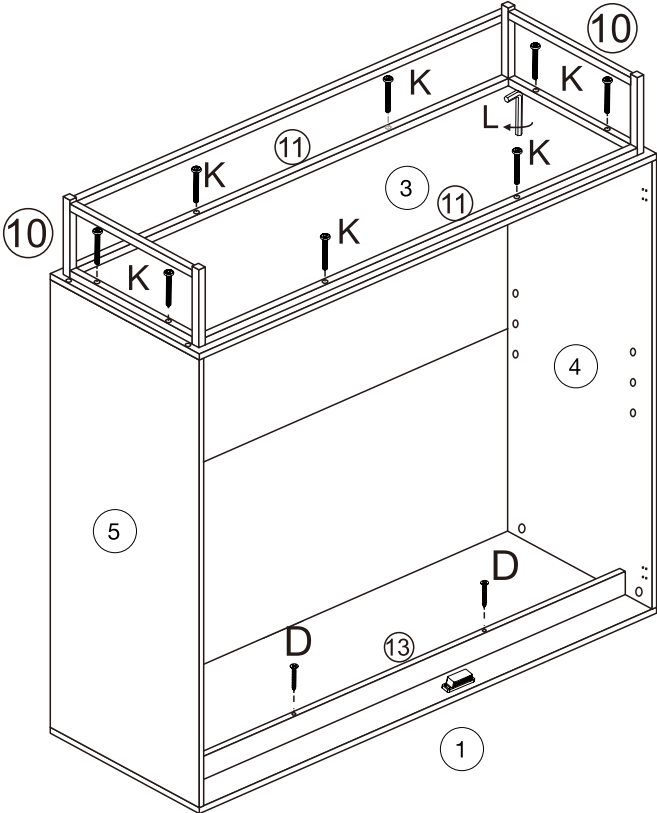

ASSEMBLY STEPS

STEP 9.

Fix doors 8 and 9 to assembled unit with hinges and screws (H), as shown.

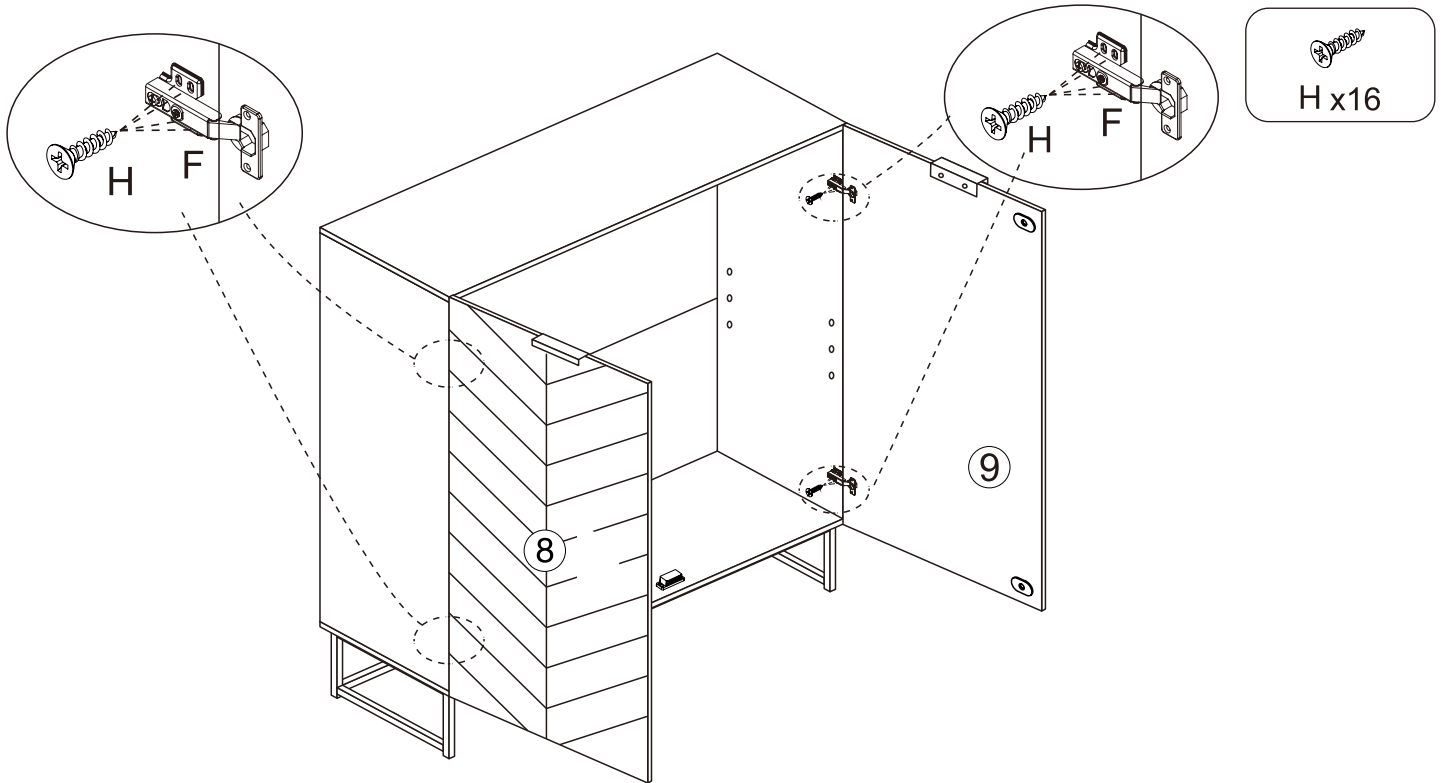

STEP 10.

Fit shelf supporters (G) to the inside of cabinet, as shown.
Place shelf 2 on top of shelf supporters, as shown.

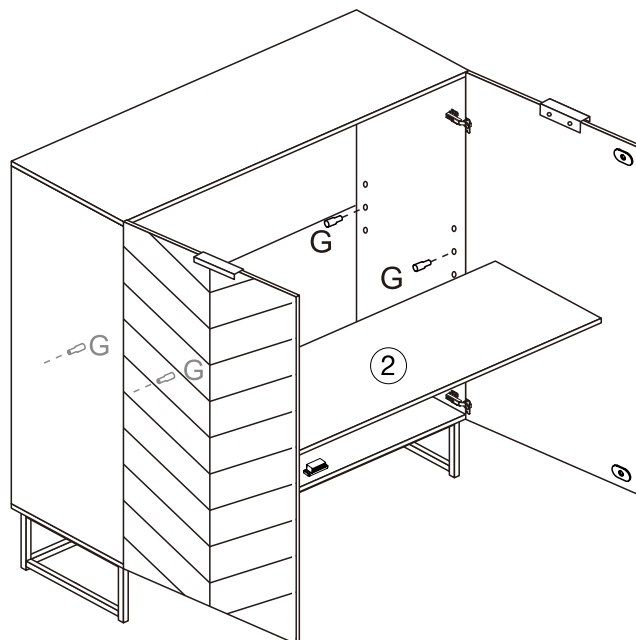

ASSEMBLY STEPS

STEP 11.

For extra stability, you must fix your Cabinet to the wall using hardware (D, M and P), as shown. Screws (D) are fixed through washers (M) and wall straps and into the wall plugs (P). Should you choose not to affix the product to the wall, serious injury may be caused if the product tips over.

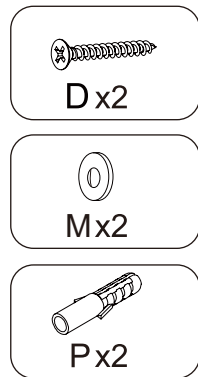
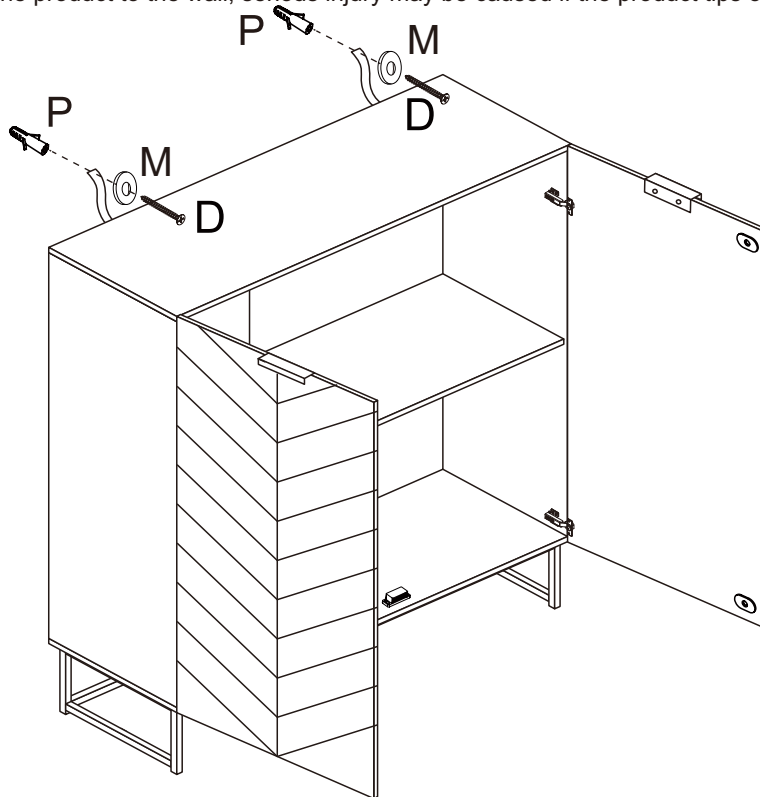

STEP 12.

